

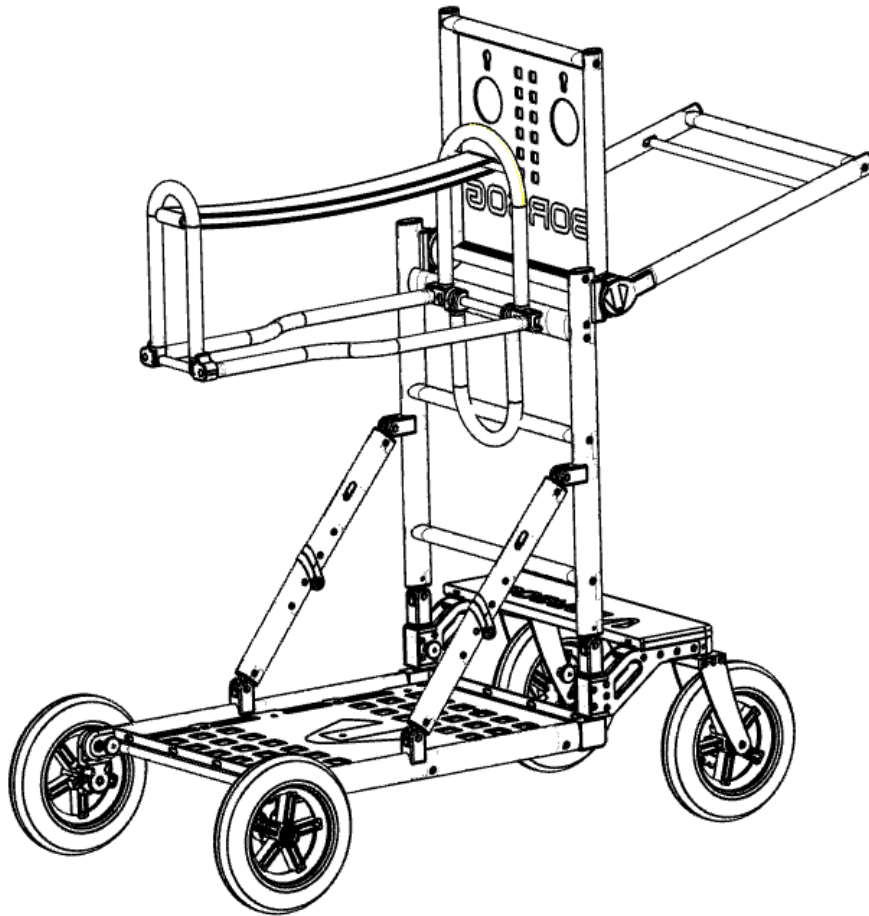

**MULTI PURPOSE CART BORSOG ONE  
PREPARATION FOR OPERATION**

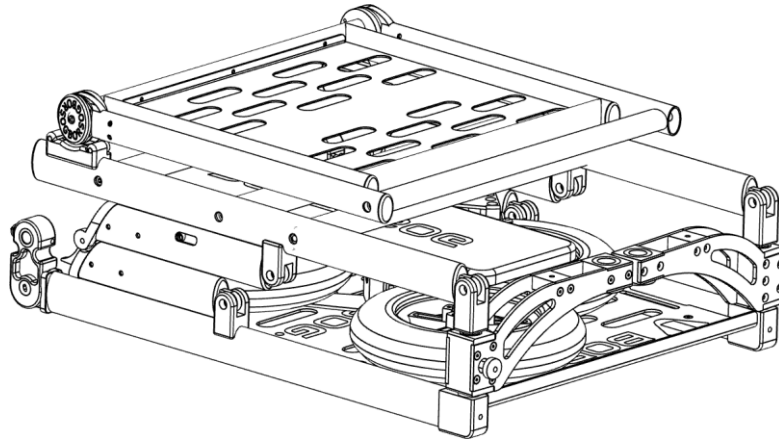

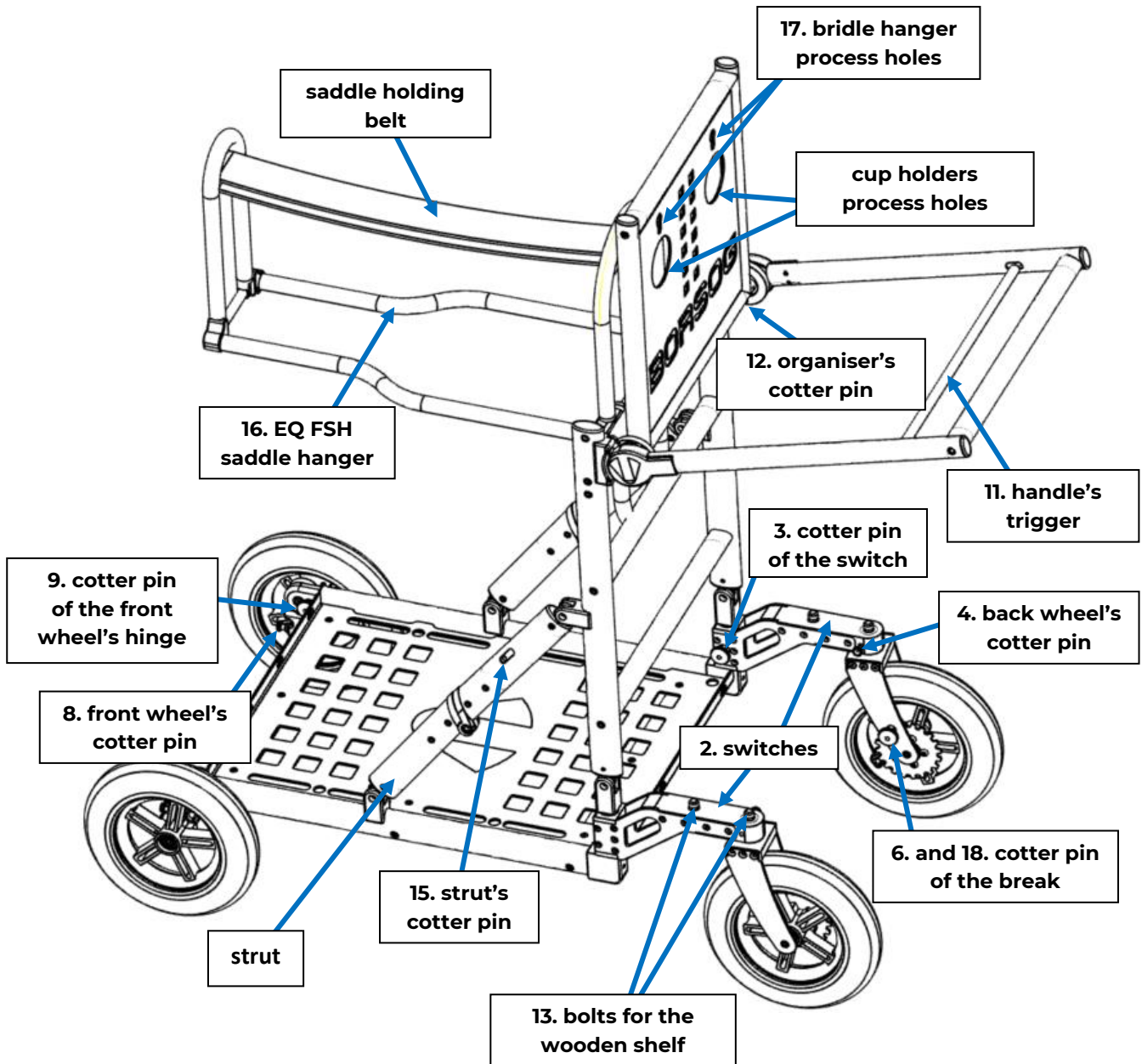



**Please read the Safe Operation Instruction before unfolding the cart for the first time.**

1. Place the folded cart vertically, with the switches turned upwards.
2. Unfasten the transport belt and create a triangle out of the construction.

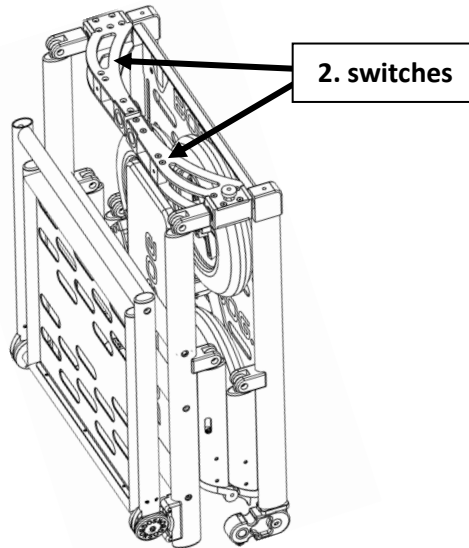

3. Pull the cotter pins of the switches and unfold the switches to the 90° angle. They should click and get locked in the working position.
4. Take the back wheels out of the bag placed inside the folded cart. Fix the wheels by pulling and releasing their cotter pins.
5. Place the cart in the horizontal position.
6. Lock the break by pulling and twisting the red cotter pins in the back wheels.

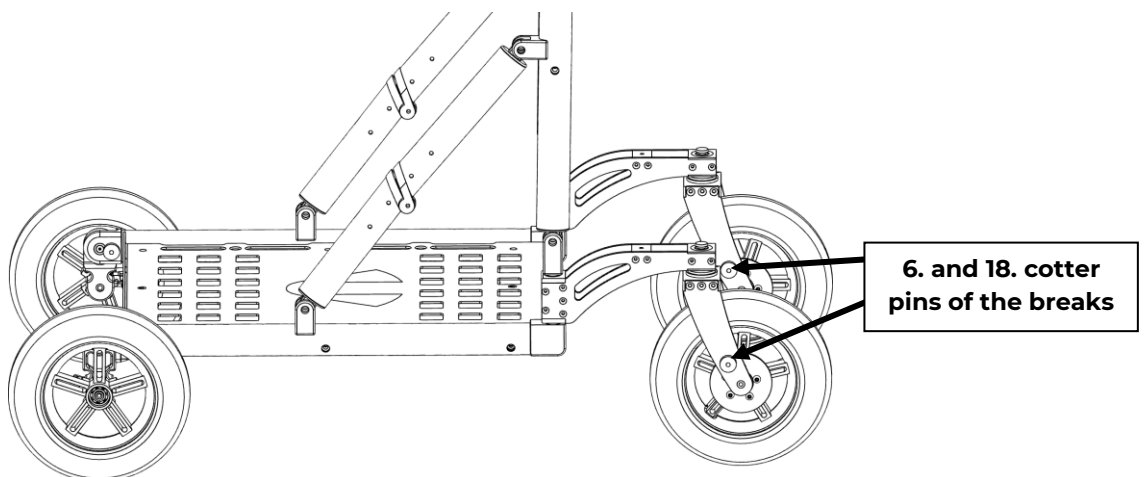



7. Go to the front of BORSOG ONE and take the front wheels out of the bag placed inside the cart.
8. Fix one front wheel in the hinge by pulling out and releasing its cotter pin. In order to make this process easier, place one foot under the front profile of the cart to lift it by a few centimetres.
9. Pull the cotter pin of the front wheel's hinge and twist it by 180°. You will hear a click of the cotter pin when the wheels are locked in the working position.

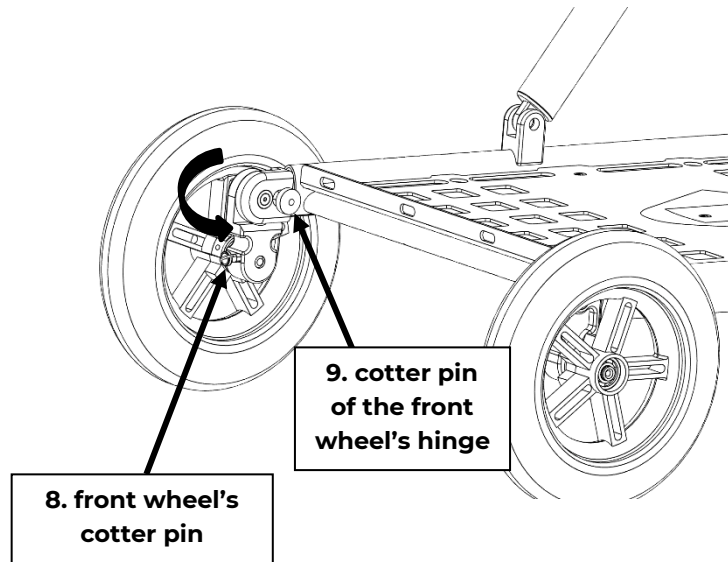

10. Repeat points 8 and 9 for the other front wheel.
11. Stand next to the cart. Push the handle's trigger and lift it.
12. Pull the organiser's cotter pins (they are placed under it, on the other side of the crossbar) and twist the organiser by 180°. It should click and lock in the working position.
13. Take the shelf, go to the back of the cart and fix it by inserting the bolts on the switches in the shelf's holes (by moving it to the front).
14. Lift the construction while holding the fixed handle (you can hold the shelf with your leg to make this movement easier).
15. Lift the struts' cotter pins and straighten them at the same time. They should click and lock into the working position.
16. Take the EQ FSR saddle rack from the ladder. Unfold it and fix it as follows:
  - a. Unfasten the belt and place it temporarily on the organiser.
  - b. Place the back roll-bars in the proper position by twisting them by 270° (move the bigger one upwards, and the smaller one downwards).
  - c. Fix the hanger on the cart by placing the bolts in the process holes of the upper ladder's crossbar.
  - d. Pull the belt through the crossbars of the upper roll-bars and fasten it appropriately blocking the crossbars in the working position at the same time.



**Make sure the buckle is at the bottom.**

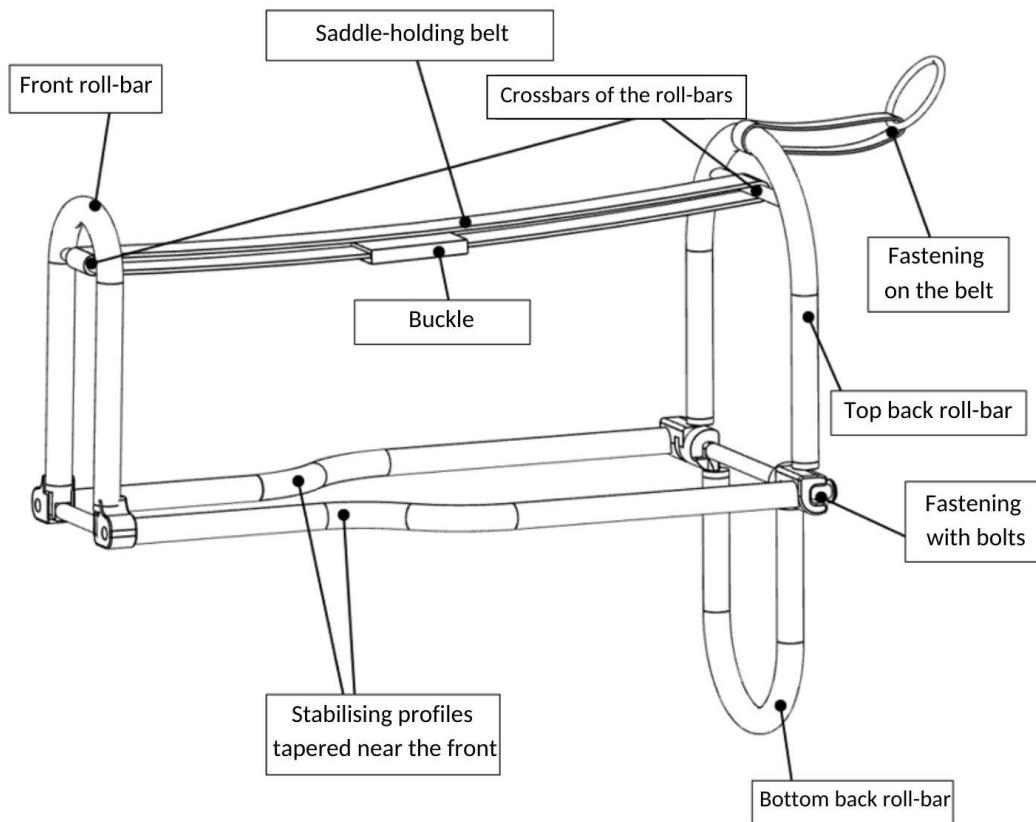

17. Fix all the additional accessories (fix the EQ FSPR saddle pads rail in the process holes on the right side of the ladder, fix the EQ ABH bridle hanger in the process holes in the organiser) and place all your equipment on the cart.
18. Unlock the break by pulling out and twisting the red cotter pins in the back wheels.

